



Features

- +Single Flavor.
- +Can serve Yogurt & Soft Ice Cream.

Mix Hopper

- +One, 3liter (0.8gallon) capacity.
- +Maintain the temperature of mix, under 5° C (41° F) in Auto & Stand by mode.

Freezing Cylinder

- +One, 1.4liter (0.37gallon) capacity.

Compact size

- +Mini sized machine secures room for limited space.

Pasteurization Function



- +Pasteurization involves heat treatment system to kill bacteria, maintaining dairy products up to two weeks.

Agitator

- +Keeps ice cream mix from liquid separation.
- +Circulates the ice cream mix evenly for temperature maintenance.



"Compact design"
300 x 775 x 750mm

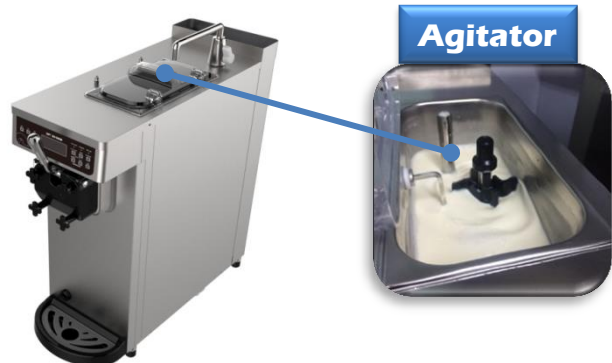

Drawings

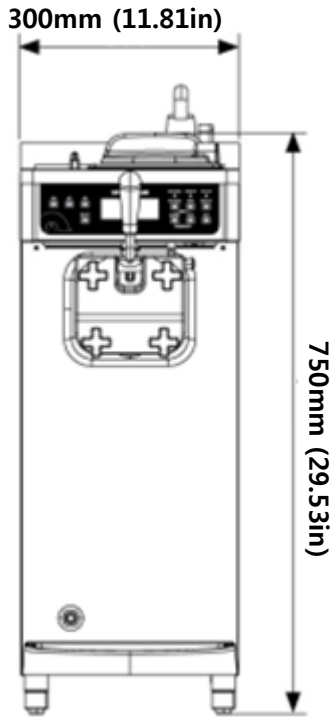

Front Side View

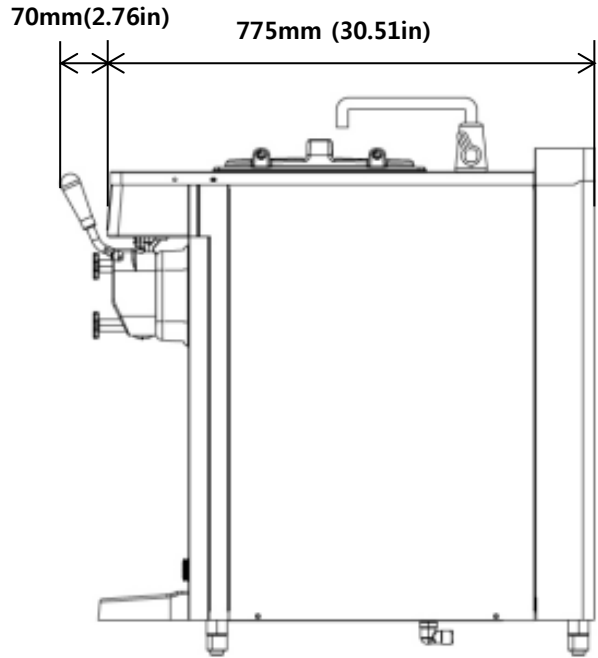

Right Side View

Exterior

Dimensions	Net		Gross	
	mm	inch	mm	inch
Width	300	11.81	380	14.96
Depth	775	30.51	870	34.25
Height	750	29.53	1,030	40.55

*Gross dimensions are based on the carton box size (no wooden packing).

Weight	Kgs	lbs
BEFORE PACKING	93	205.03
AFTER PACKING	104	229.28

Electrical

Power consumption	1,400 Watt
Voltage	208~230V/60HZ/1PH 220~240V/50HZ/1PH

Specifications

Comp	No.	Brand	Watt	BTU	Ref.
Freezing	1	EMBRACO	1536	5241	R-404A

*Air-Cooling condenser.

*BTUs may vary depending on compressor used.

Production Capacity

Max. Production	12kg (26.46lbs / h)
First Dispensing	6~8min
Consecutive Dispensing	5~6 cups(100cc/3.5oz)

*Production Capacity may vary depending on ambient temperature.

Dasher Motor

One, 0.37Kw (0.5Hp)

*Product's exterior and specifications can be modified without prior notice.

www.AustralianSlushMachines.com.au

Phone 0447587446